

PA-XAG3FC-QD Data Sheet (Ver B)

44 pin QFP socket/40 pin DIP 0.6" plug

Supported Device/Footprints

These adapters accept 44 pin QFP versions of the Philips 51 XAG3 and plug into an 87C51FC 40 pin DIP footprint.

Device		Footprint	
Manufacturer	Device	Device	Package
Philips	51XA-G3QFP	87C51FC	40 DIP 0.6"

There have been 3 versions of the XA-G3. Each version has slightly different programming requirements. These adapters support all 3 versions. The version are identified by their mask code. See the Jumper Settings section.

WARNING XSC6630 REQUIRES 10.75V VPP

The QFP socket accepts packages with the dimensions listed below:

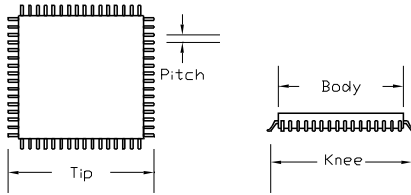

Body	Knee	Tip	Pitch
10.0 mm typical	11.0 mm typical 11.6 maximum	12 mm typical 13.2 maximum	0.8 mm

Adapter Dimensions

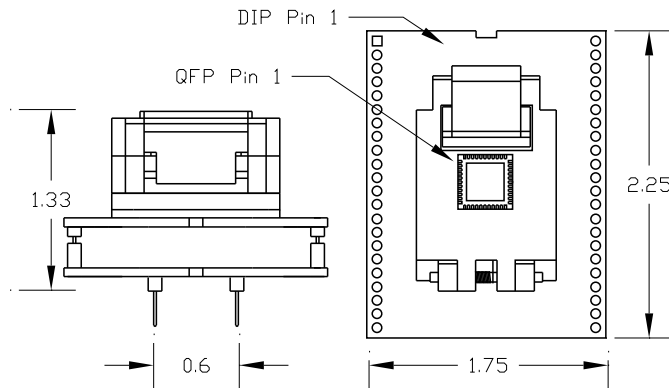

Memory Map

Both the 51XA-G3 and the 87C51FC (FC) contain 32K bytes of EPROM. Using the FC algorithm all of the 51XA-G3's EPROM (0000-7FFF) can be programmed.

Jumper Settings

There are two jumper blocks on the bottom board (XAG3-FC ver B). Set them according to the following chart to support the three known versions of the XA-G3 device. **The Mask Code is typically marked on the device's package.**

Mask Code	VPP	JP1	PSEN	JP2
XSC6389	12.75V	2-3	Low	X
XSC6503	12.75V	2-3	High pulse then Low	Open
XSC6630	10.75V	1-2	Low	X

X = Don't Care

JP1 controls a 2.0V step down. With pins 1-2 connected the stepdown is enabled.

JP2 isolates device PSEN from programmer PSEN. Leave it open.

Adapter Construction

The adapter is made up of 3 sub-assemblies. They assemble via connectors making the adapter modular. This way the sub-assemblies can be replaced when they wear out.

When disassembling the adapter take care not to bend the pins. When reassembling the adapter note the pin 1 indicators to align the parts correctly.

Test Socket

QFP lidded test socket:

Enplas Part #: FPQ-44-0.65-06T

LSC #: 44-06T

44QFP-6T

Accepts the test socket and connects to the bottom board.

XAG3-FC, VerB

Performs the wiring shown in the Adapter Wiring section.



Logical Systems Corporation
PO Box 6184, Syracuse, NY 13217-6184 USA
Tel (315) 478-0722, FAX (315) 479-6753
S Y S T E M S www.logicals.com, Email: info@logicals.com

PA-XAG3FC-QD Data Sheet
Doc: XAG3FCQB.DOC
Rev 5/14/97
Page 1 of 2

Adapter Wiring

The following chart shows the connections from the QFP device to the adapter's DIP plug.

Adapter Socket		Adapter Plug	
51XAG3-QFP		87C51-FC-DIP	
Pin	Signal	Pin	Signal
1	P1.5	-	
2	P1.6	-	
3	P1.7	-	
4	RST*	20	VSS
5	P3.0	21	P2.0/A8
6	-	-	
7	P3.1	22	P2.1/A9
8	P3.2	23	P2.2/A10
9	P3.3	24	P2.3/A11
10	P3.4	25	P2.4/A12
11	P3.5	26	P2.5/A13
12	P3.6	14	P3.4/A14
13	P3.7	-	
14	XTAL2	18	XTAL2
15	XTAL1	19	XTAL1
16	VSS	20	VSS
17	VDD	40	VDD
18	P2.0	1	P1.0/A0
19	P2.1	2	P1.1/A1
20	P2.2	3	P1.2/A2
21	P2.3	4	P1.3/A3
22	P2.4	5	P1.4/A4
23	P2.5	6	P1.5/A5
24	P2.6	7	P1.6/A6
25	P2.7	8	P1.7/A7
26	PSEN* !!	29	PSEN*
27	ALE/PGM*	30	ALE/PGM*
28	-	-	
29	EA*/VPP !	31	EA*/VPP
30	P0.7	32	P0.7/D7
31	P0.6	33	P0.6/D6
32	P0.5	34	P0.5/D5
33	P0.4	35	P0.4/D4
34	P0.3	36	P0.3/D3
35	P0.2	37	P0.2/D2
36	P0.1	38	P0.1/D1
37	P0.0	39	P0.0/D0
38	VDD	40	VDD
39	VSS	20	VSS
40	P1.0	27	P2.6
41	P1.1	28	P2.7
42	P1.2	16	P3.6
43	P1.3	17	P3.7
44	P1.4	13	P3.3

! VPP has a voltage dropping circuit that is controlled by JP1. With pins 1-2 connected the 2.0V drop is enabled. With pins 2-3 connected, device pin 29 is connected to programmer pin 31.

!! The device's PSEN pin (pin 26) has a pulse generating circuit attached to it. With JP2 open the circuit generates a short pulse on the device's PSEN at power up. With JP2 shorted, the device and programmer PSEN signals are connected and the programmer controls the signal.

For all three versions JP2 should be left open.