

PA552-68(Z) Data Sheet

68 pin PLCC socket/40 pin DIP 0.6" plug

Supported Device/Footprints

Using this adapter, several 68 pin microcontrollers in either PLCC or CLCC package can be programmed 40 pin DIP programmers

Device			Footprint	
Mfgr	Device	Package	Device	Plug
Philips	87C552 (8K)	PLCC,	87C51FA (8K)	40 pin DIP
	87C554 (16K)	CLCC	87C51FB (16K)	
Dallas	87C550 (8K)	PLCC	87C51FA (8K)	40 pin DIP

Adapter Dimensions

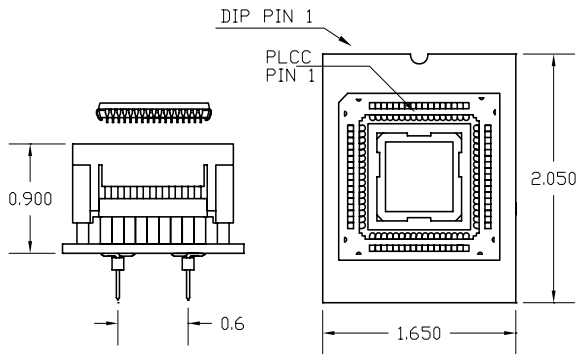

Press rim to open socket, press device to close

PA552-68

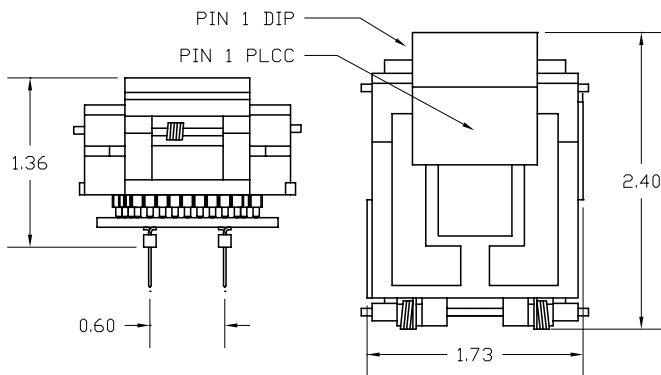

PA552-68Z

Adapter Construction

The adapter is made up of 2 sub-assemblies. They assemble via connectors making the adapter modular. This way the sub-assemblies can be replaced when they wear out.

When disassembling the adapter take care not to bend the pins. When reassembling the adapter note the pin 1 indicators to align the parts correctly.

The following chart shows the socket and board part numbers that make up this adapter.

Adapter	Test Socket	Circuit Board	DIP Plug
PA552-68	68-304	552-68	0.6"
PA552-68Z	68-390	552-68Z	0.6"

Test Socket

LSC #	Mfgr/Part Number	Style
68-304	Yamaichi IC120-0684-304	Open Top
68-390	Yamaichi IC51-0684-390	Lidded ZIF

Adapter Wiring

The following chart shows the connections from the PLCC device to the adapter's DIP plug.

DEVICE	SIGNAL	PLUG	PLUG	SIGNAL	DEVICE
1	P5.0	-	-	P5.1	68
2	VCC	40	-	P5.2	67
3	STADC	-	-	P5.3	66
4	PWM0	-	-	P5.4	65
5	PWM1	-	-	P5.5	64
6	EW	-	-	P5.6	63
7	P4.0	-	-	P5.7	62
8	P4.1	-	-	AVDD	61
9	P4.2	-	-	AVSS	60
10	P4.3	-	-	AVREF+	59
11	P4.4	-	-	AVREF-	58
12	P4.5	-	39	P0.0/D0	57
13	P4.6	-	38	P0.1/D1	56
14	P4.7	-	37	P0.2/D2	55
15	RESET	9	36	P0.3/D3	54
16	P1.0/A0	1	35	P0.4/D4	53
17	P1.1/A1	2	34	P0.5/D5	52
18	P1.2/A2	3	33	P0.6/D6	51
19	P1.3/A3	4	32	P0.7/D7	50
20	P1.4/A4	5	31	VPP/EA*	49
21	P1.5/A5	6	30	PGM*	48
22	P1.6/A6	7	29	PSEN*	47
23	P1.7/A7	8	28	P2.7	46
24	P3.0	10	27	P2.6	45
25	P3.1	11	26	P2.5	44
26	P3.2	12	25	P2.4/A12	43
27	P3.3	13	24	P2.3/A11	42
28	P3.4	14	23	P2.2/A10	41
29	P3.5	15	22	P2.1/A9	40
30	P3.6	16	21	P2.0/A8	39
31	P3.7	17	-	NC	38
32	NC	-	20	GND	37
33	NC	-	20	GND	36
34	X2	18	19	X1	35