

PA51CC2-xDx Data Sheet

28 pin SO (or PLCC) socket/40 pin DIP 0.6" plug

Supported Device/Footprints

Using one of these adapters, the Atmel T89C51CC02 in either SOIC or PLCC package can be programmed using the 40 pin DIP footprint specified by Atmel.

For this adapter to be useful, a programmer must offer specific support for this device and adapter combination.

Atmel: AT89C51CC02 PLCC28 or SO28

Footprint: Atmel specified 40 DIP 0.6"

Device			Footprint	
Mfgr	Device	Package	Device	Plug
Atmel	T89C51CC02	SOIC, PLCC	T89C51CC02	40 DIP

Adapter Dimensions

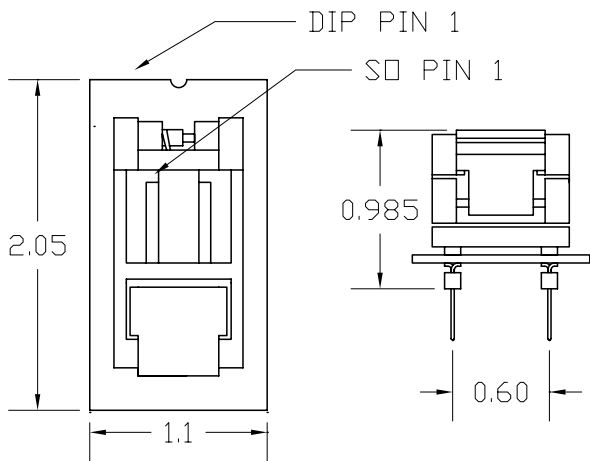

PA51CC2-SD

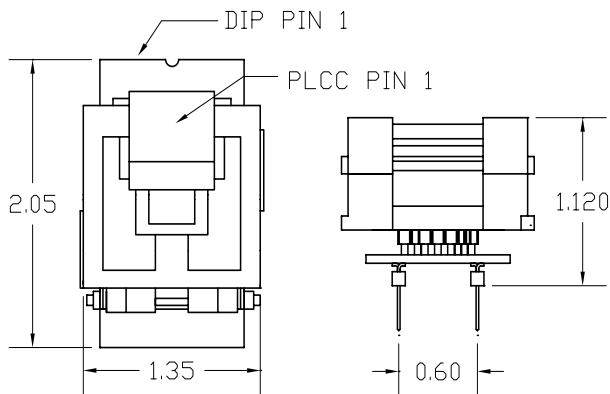

PA51CC2-PDZ

Adapter Construction

These adapters are made up of 2 sub-assemblies. They assemble via connectors making the adapter modular. This way the sub-assemblies can be replaced easily.

When disassembling the adapter take care not to bend the pins. When reassembling the adapter note the pin 1 indicators to align the parts correctly.

Adapter	Test Socket	Circuit Board
PA-51CC2-PDZ	28-399	28Z40CC2
PA-51CC2-SD	28SD-08	28S40CC2

Test Socket

LSC Socket	Style	Mfgr/Pn
28-399	Lidded ZIF	Yamaichi IC51-0284-399
28SD08	Lidded ZIF	Enplas FP-28-1.27-08

Adapter Wiring

The following chart shows the connections from the SOIC or PLCC device to the adapter's DIP plug.

DEVICE	SIGNAL	PLUG
1	VSS	20
2	N/C	-
3	N/C	-
4	P4.1	24
5	P4.0	23
6	P2.1	22
7	P3.7	17
8	P3.6	16
9	P3.5	15
10	P3.4	14
11	P3.3	13
12	P3.2	12
13	P3.1	11
14	P3.0	10
15	XTAL2	18
16	XTAL1	19
17	VCC	40
18	VSS	20
19	RST	9
20	P2.0	21
21	P1.7	8
22	P1.6	7
23	P1.5	6
24	P1.4	5
25	P1.3	4
26	P1.2	3
27	P1.1	2
28	P1.0	1