

PA5122-QD Data Sheet

64 pin QFP socket/40 pin DIP 0.6" plug

Supported Device/Footprints

Using this adapter, the Atmel AT89C5122 in the QFP package can be programmed using the 40 pin DIP footprint specified by Atmel.

For this adapter to be useful, a programmer must offer specific support for this device and adapter combination.

Atmel: AT89C5122 QFP64 (Pkg. Code R02 R07)

Footprint: Atmel specified 40 DIP 0.6"

Device			Footprint	
Mfgr	Device	Package	Device	Plug
Atmel	AT89C5122	QFP	AT89C5122	40 DIP

The QFP socket accepts packages with the dimensions listed below:

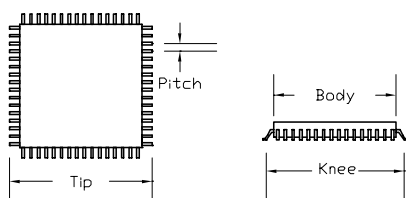

Body	Knee	Tip (lead span)	Pitch
10.0 mm typ	11 mm typ	12 mm typ	0.5 mm

Adapter Dimensions

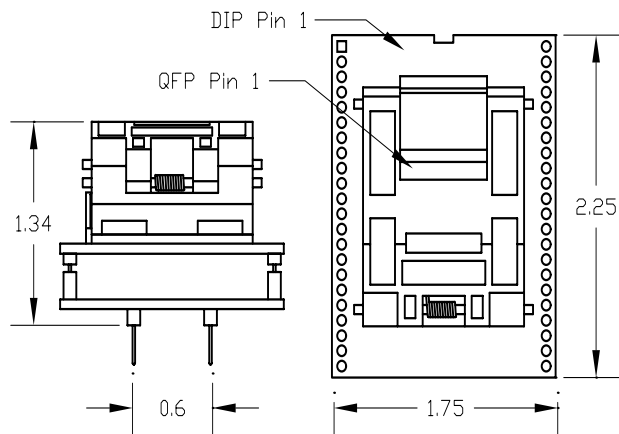

PA5122-QD

Adapter Construction

These adapters are made up of 3 sub-assemblies. They assemble via connectors making the adapter modular. This way the sub-assemblies can be replaced easily.

When disassembling the adapter take care not to bend the pins. When reassembling the adapter note the pin 1 indicators to align the parts correctly.

Adapter	Test Socket	Top Board	Bottom Board
PA5122-QD	64QJ-807	5122-64Q	P64-QD

Test Socket

LSC Socket	Style	Mfgr/Pn
64QJ-807	Lidded ZIF	Yamaichi IC51-0644-807

Adapter Wiring

The following chart shows the connections from the QFP device to the adapter's DIP plug.

DEVICE	SIGNAL	PLUG	PLUG	SIGNAL	DEVICE
1	DVCC	-	1	P1.0	64
2	P1.2	3	31	EA	63
3	P1.1	2	8	P1.7	62
4	P5.7	-	TP*	VAREF	61
5	P5.6	-	-	D-	60
6	P1.5	6	-	D+	59
7	P5.5	-	21	P2.0	58
8	P5.4	-	22	P2.1	57
9	P1.3	4	23	P2.2	56
10	P5.3	-	40	AVCC	55
11	P5.2	-	-	PLLIF	54
12	P1.4	5	20	AVSS	53
13	P5.1	-	24	P2.3	52
14	P5.0	-	25	P2.4	51
15	PSEN	29	26	P2.5	50
16	VSS	20	27	P2.6	49
17	CVCC	-	11	P3.1	48
18	LI	-	7	P1.6	47
19	CVSS	20	28	P2.7	46
20	VCC	40	10	P3.0	45
21	ALE	30	15	P3.5	44
22	P0.7	32	12	P3.2	43
23	P0.6	33	-	P4.0	42
24	P0.5	34	13	P3.3	41
25	P0.4	35	-	P4.1	40
26	P3.7	17	14	P3.4	39
27	P0.3	36	-	P4.2	38
28	P0.2	37	-	P4.3	37
29	P0.1	38	16	P3.6	36
30	P0.0	39	-	P4.4	35
31	XTAL1	19	9	RST*	34
32	XTAL2	18	-	P4.5	33

TP* : The VAREF pin was left unassigned in the programming adapter specification (QFP64-DIL40.PDF; 9/10/03). A test point with available VCC and VSS connections is provided.



Logical Systems Corporation
 PO Box 6184, Syracuse, NY 13217-6184 USA
 Tel (315) 478-0722, FAX (315) 479-6753
 www.logicalsyst.com, Email: info@logicalsyst.com

PA5122-QD Data Sheet
 Doc: 5122-QD.DOC
 Rev 10/30/2003
 Page 1 of 1