

PA5114-20SO Data Sheet

20 pin SOIC socket/40 pin DIP plug

Supported Device/Footprints

Using these adapters ATMEL AT89C5114 devices in 20 pin SOIC packages can be programmed using the 40 pin DIP footprint specified by Atmel.

For this adapter to be useful, a programmer must offer specific support for this device and adapter combination.

Atmel: AT89C5114, AT89C5116 SOIC 20

Footprint: Atmel specified 40 DIP

The SOIC socket accepts packages with the dimensions listed below:

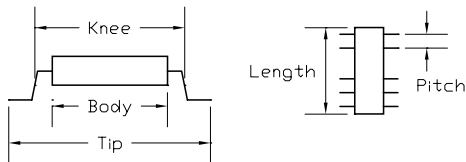

Body mm (inches)			Knee mm (inches)		
min.	typ.	max.	min.	typ.	max.
7.4	7.8	7.9	n/a	9.3	9.4
(0.291)	(0.307)	(0.311)		(0.366)	(0.370)

Tip mm (inches)			Body Length	Lead Pitch
min.	typ.	max.		
10.0	11.6	n/a	n/a	1.27
(0.394)	(0.457)			

Adapter Dimensions

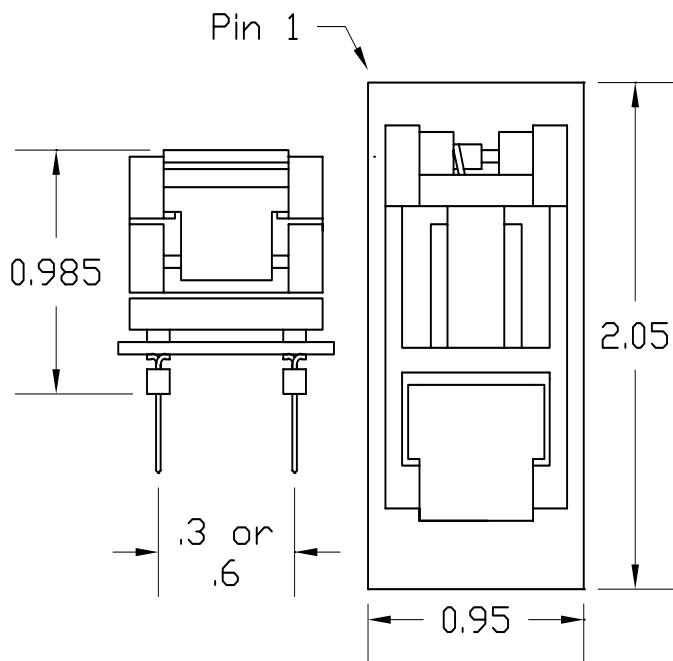

PA5114-20SO

Adapter Construction

The adapter is made up of 2 sub-assemblies. They assemble via connectors making the adapter modular. This way the sub-assemblies can be replaced easily.

When disassembling the adapter take care not to bend the pins. When reassembling the adapter note the pin 1 indicators to align the parts correctly.

The following chart shows the various socket and board part numbers that make up these adapters.

Adapter	Plug	Test Socket	Board
PA5114-20SO	0.6"	20(28H)SD-08	5114SO20

Test Socket

LSC #	Style	Mfgr/Pn
20(28H)SD-08	Lidded	Enplas FP-20(28H)-1.27-08

Adapter Wiring

The following chart shows the connections from the SOIC device to the adapter's DIP plug.

20SOIC	SIGNAL	40DIP	40DIP	SIGNAL	20SOIC
1	P4.0	1	-	N/C	20
2	P4.1	2	40	Vcc	19
3	P4.2	3	20	Vssa	18
4	P4.3	4	-	N/C	17
5	P3.3	13	-	N/C	16
6	P3.4	14	18	XTAL2	15
7	P3.5	15	19	XTAL1	14
8	P3.2	12	9	RESET*	13
9	P3.1	11	20	Vss	12
10	P3.0	10	40	Vcc	11